

Creating PostScript Files **Adobe Pagemaker 6.5 for the Macintosh**

Adobe PageMaker 6.5 documents must be saved as PostScript files in order for *Preps* to process them. PostScript files that are created from PageMaker 6.5 documents are saved as color composite files, and can contain:

- Color
- Bleeds
- OPI links
- DCS links

NOTE:

If your document contains embedded color TIFF images, you must select a color output device to retain the color information in the PostScript file. If you select an output device that does not support color, PageMaker 6.5 will convert the TIFF images in your document to grayscale. *Color General* works as a color output device.

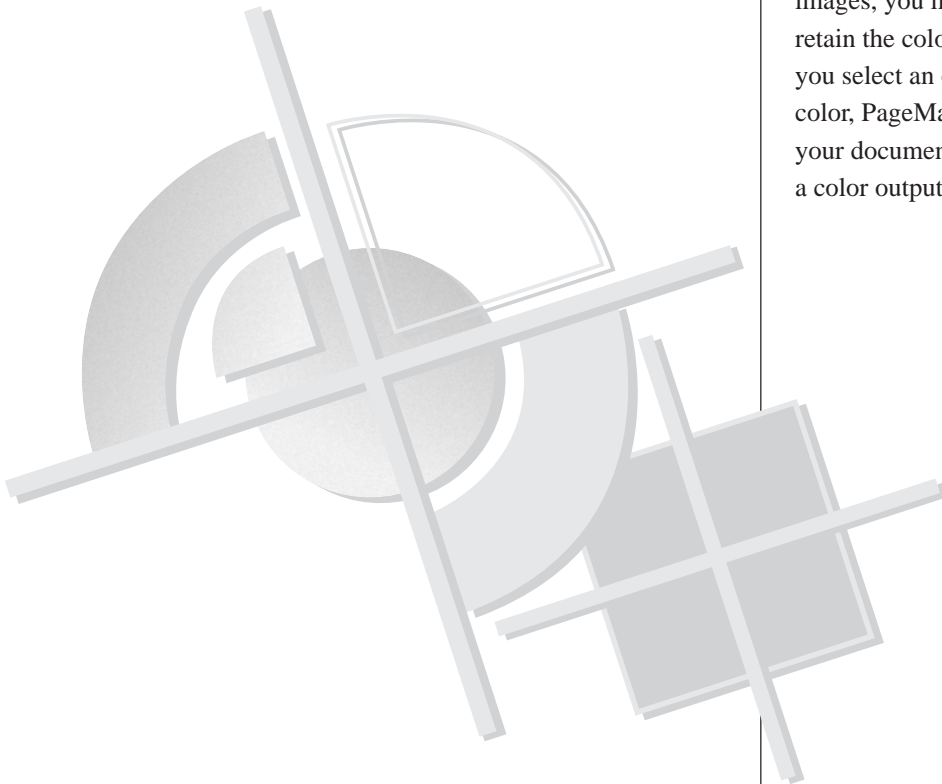

CREATING A PRINTER STYLE

To ensure consistent printing to file, we recommend that you create a printer style. A printer style allows you to repeatedly use a range of selected printer options without having to re-choose them every time you want to create a PostScript file. Follow the steps below to create a printer style.

To create a printer style

- ▶ From the *File* menu, choose *Printer Styles, Define*.
- ▶ In the *Define Printer Styles* dialog box, choose the *New* button.
- ▶ In the *Name* box, type a name for the printer style, choose *OK*.
- ▶ In the *Define Printer Styles* dialog box, choose the *Edit* button.

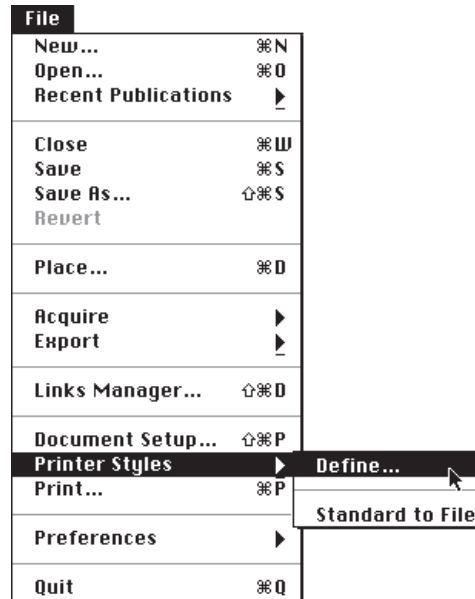

SELECTING PRINT OPTIONS

To select print options

- ▶ From the *PPD* list, select *Color General*.
- ▶ In the *Copies* box, type *1*.
- ▶ Clear the *Collate, Reverse, Proof* and *Reader's spreads* check boxes.
- ▶ Select the range of pages you want to print.
- ▶ From the *Print* list, select the pages you want to print (Even, Odd, or Both).
- ▶ Select *Ignore "Non-Printing" setting, Print blank pages* and *Book* options as needed.
- ▶ In the *Orientation* area, select the *Portrait* icon.

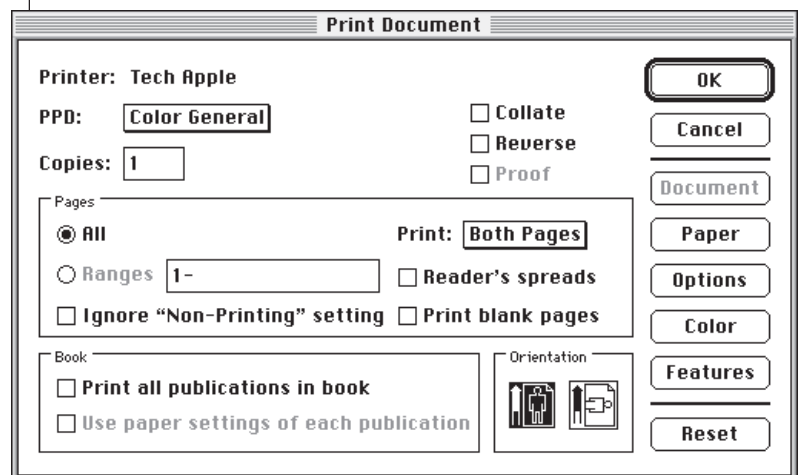

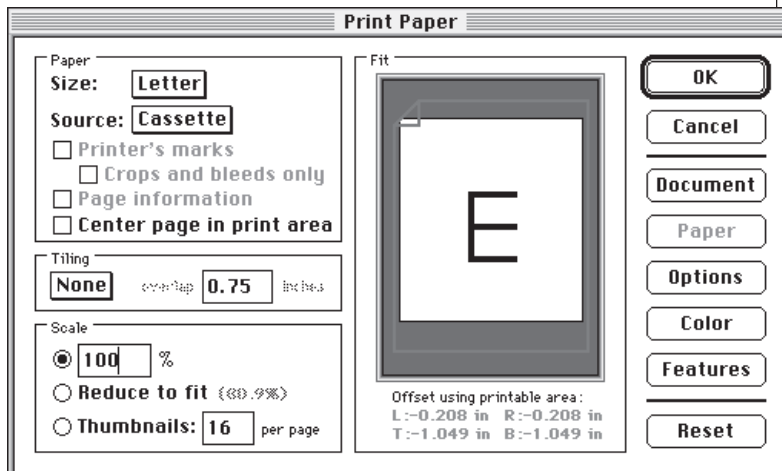

To choose scaling and paper size options

- ▶ In the *Print Document* dialog box, choose the *Paper* button.
- ▶ From the *Size* list, select *Letter*.
- ▶ From the *Source* list, select *Cassette*.
- ▶ Clear the *Center page in print area* check box.
- ▶ From the *Tiling* list, select *None*.
- ▶ In the *Scale* area, select the *100%* option button.

Note:

Since PageMaker receives information about the document's page size from the *Document Setup* dialog box, it doesn't matter what paper size you select when you create the PostScript file when following these instructions.

Selecting graphics and font options

The following table lists the available graphics and font options, and the method for selecting them in PageMaker 6.5.

To:	Do the following:
Embed images	Select <i>Normal</i>
Link TIFF images	Select <i>Omit images</i>
Embed TIFF images adjusted to the highest resolution supported by output device	Select <i>Optimized Subsampling</i>
Embed low-resolution TIFF images	Select <i>Low resolution</i>
All image options include OPI tags for TIFF images.	
Include all fonts	Select <i>PostScript and TrueType</i>
Include TrueType fonts	Select <i>TrueType only</i>
Omit all fonts	Select <i>None</i>

To select graphics and font options

- ▶ In the *Print Paper* dialog box, choose the *Options* button.
- ▶ From the *Send image data* list, select *Normal*.
- ▶ From the *Data encoding* list, select *Send ASCII image data*.
- ▶ From the *Download fonts* list, select *None*.
- ▶ Select the *Use symbol font for special characters* check box.
- ▶ Clear the *Include PostScript error handler* check box.
- ▶ Select the *Write PostScript to file* check box.
- ▶ Select the *For prepress* option button.
- ▶ If either *Extra image bleed* or *Launch post-processor* check box are selected, clear them.
- ▶ Choose *OK*.

NOTE:

Set *Send image data*, *Data encoding* and *Download fonts* as required.

To save the printer style

- ▶ In the *Define Printer Styles* dialog box, choose *OK*.

The print options you selected in the *Print Document* dialog box are now saved as the printer style you named earlier. You can use the printer style by following the steps below.

To use the printer style

- ▶ From the *File* menu, choose *Printer Styles*, select the printer style you want to use.
- ▶ Choose the *Options* button.
- ▶ In the *Print Options* dialog box, choose the *Save As* button.
- ▶ Select the location in which you want to save the PostScript file and enter a name.
- ▶ Choose *OK*.
- ▶ Choose the *Save* button.

A color composite PostScript file has been created from a PageMaker 6.5 document, and can be added to *Preps* as a source file.

